



ASPIRATORI DI GRANULI MONOFASE E TRIFASE



SAL-6U



SAL-3U-E



SAL-U Series

■ Specifications

Model	SAL-1U	SAL-3U	SAL-6U	SAL-12U	SAL-1.5U-E	SAL-3U-E	SAL-6U-E	SAL-12U-E	SAL-3U-3	SAL-6U-3
Motore	Carbon brush								Inductive	
Potenza Motore (kW, 50/60Hz)	0.46/0.55	1.15/1.32	1.15/1.32	1.15/1.32	1.15/1.32	1.15/1.32	1.15/1.32	1.15/1.32	0.37/0.42	0.75/0.85
Lunghezza Tubazione mt	1.5	1.5	1.5	1.5	1.5	1.5	1.5	1.5	1.5	1.5
Produzione Oraria (kg/hr)	30	200	300	400	150	200	300	400	200	300
Capacità Tramoggia (L)	1	3	6	12	1.5	3	6	12	3	6
Alimentazione	1Φ, 115/230VAC, 50/60Hz								3Φ, 230/400/460/575VAC, 50/60Hz	
Pulizia Filtro	Standard	Standard	Standard	Standard	Standard	Standard	Standard	Standard	Standard	Standard
Accumulatore Air	-	-	Optional	Optional	-	-	Optional	Optional	-	-
Dimensioni										
H (mm)	525	555	645	745	670	740	800	935	610	700
W (mm)	270	305	340	340	260	305	340	340	340	380
D (mm)	325	370	410	410	325	370	410	410	475	540
Peso (kg)	10	11	12	14	11	13	16	18	18	33

ASPIRATORI DI GRANULI TRIFASE



SAL-5HP-UG & SHR-24U

SAL-UG/UGP Series

SAL-UGP Outline Drawings

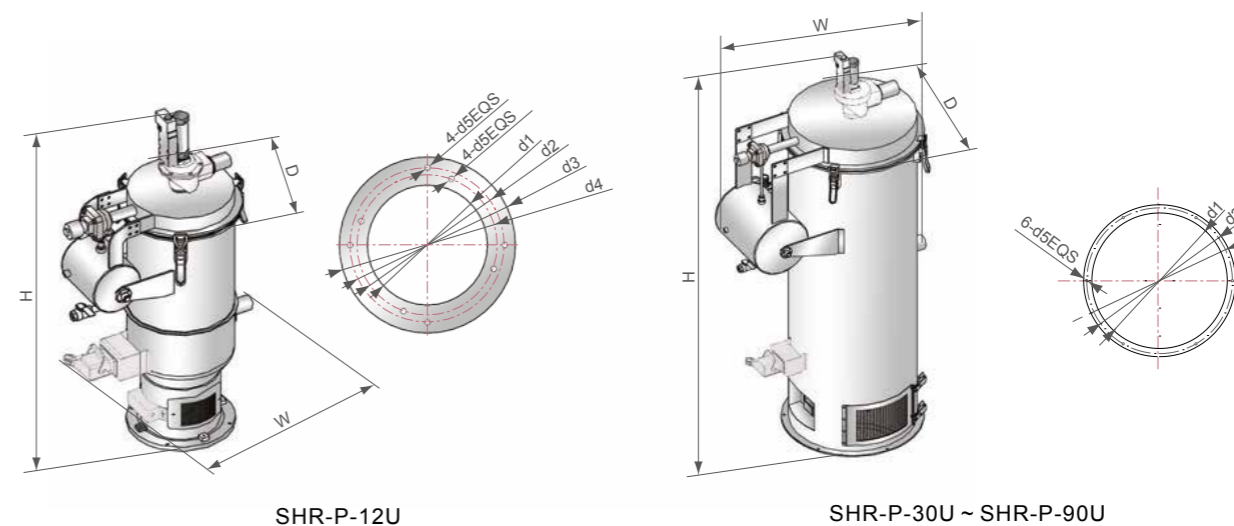

SAL-UG Specifications

Model	Main Unit				Hopper Receiver				Conveying Pipe Dia. (inch)	Air Suction Pipe Dia. (inch)	Conveying Capacity (kg/hr)
	Motor Power (kW, 50/60Hz)	Specification	Dimension (mm) H x W x D	Weight (kg)	Applied to	Hopper Capacity (L)	Dimension (mm) H x W x D	Weight (kg)			
SAL-1HP-UG	0.75/ 0.85	3Φ	1000 x 400 x 500	50	SHR-6U x 1	6	420 x 285 x 360	6	1.5	1.5	300
					SHR-6U-E x 1		600 x 275 x 360	8			
SAL-2HP-UG	1.5/ 1.8	3Φ	1000 x 400 x 500	54	SHR-12U x 1	12	470 x 315 x 400	7	1.5	1.5	500
					SHR-12U-E x 1		700 x 315 x 400	12			
SAL-3.5HP-UG	2.4/ 2.6	3Φ	1380 x 490 x 590	73	SHR-24U x 1	24	690 x 315 x 400	9	2	2	750
					SHR-24U-E x 1		1120 x 360 x 400	13			
SAL-5HP-UG	3.75/ 4.2	3Φ	1380 x 490 x 590	74	SHR-24U x 1	24	690 x 315 x 400	9	2	2	1000
					SHR-24U-E x 1		1120 x 360 x 400	13			
SAL-7.5HP-UG	5.5/ 6.3	3Φ	1830 x 585 x 675	156	SHR-36U x 1	36	930 x 315 x 400	11	2	2.5	1200
SAL-10HP-UG	7.5/ 8.6	3Φ	1830 x 585 x 675	160	SHR-36U x 1	36	930 x 315 x 400	11	2	2.5	1600
SAL-20HP-UG	13/ 18.7	3Φ	2100 x 680 x 800	226	SHR-48U x 1	48	975 x 350 x 485	15	3	3.5	2000

VALVOLA PROPORZIONALE



SPV38U e SPV-50U

“MULTI-STATION” Hopper Loader



SAL-3.5HP-UG124 & SHR-6U-S

